

USER GUIDE

INSIGNIA™

3.7 Cu. Ft. Free-Standing Gas Range for RVs

NS-RNG24SS9
NS-RNG24SS9-C

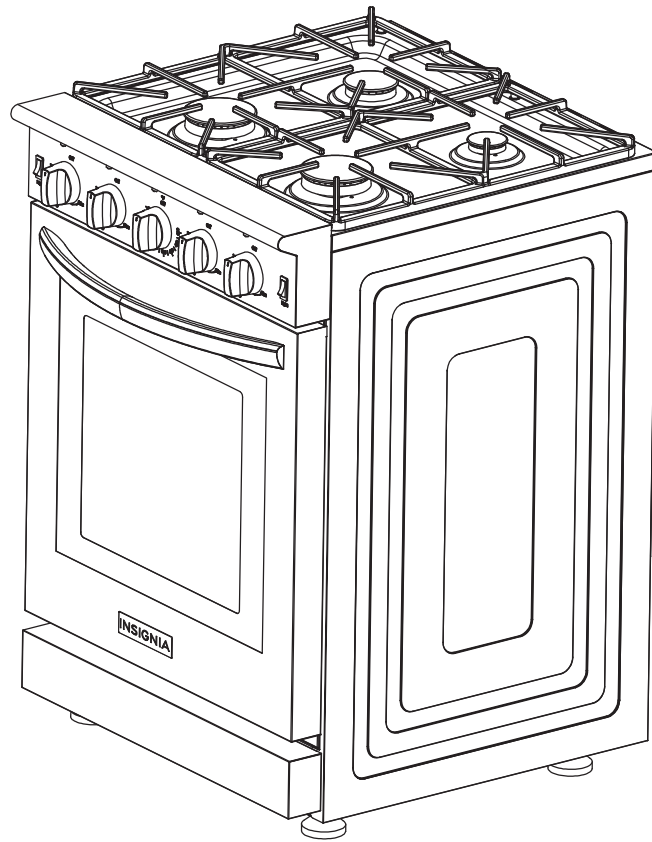

Before using your new product, please read these instructions to prevent any damage.

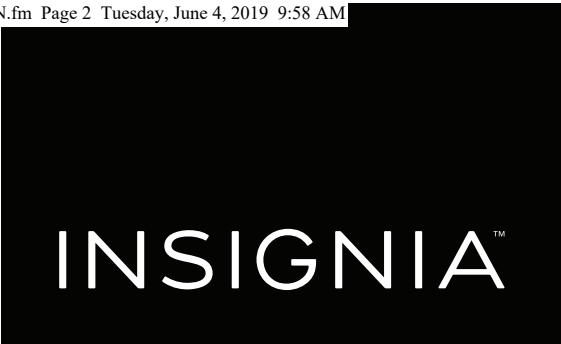

Contents

Introduction	3
IMPORTANT SAFETY INSTRUCTIONS	3
GENERAL SAFETY PRECAUTIONS	4
Installation instructions	6
Features	6
Package contents	6
Main components	6
Control panel	7
Range dimensions	7
Installation	9
Installing the range	10
Clearances and dimensions	10
Important notes to the installer:	11
Before installing the range	11
Adjusting the height and leveling the range	11
Installing the anti-tip device	12
Connecting to gas	14
Installing plastic pads to the oven back	15
Connecting to power	16
Testing for gas leaks	16
Testing top burners	17
Testing the oven burner	17
Using	18
Before you begin using your range	19
Tips for saving gas	19
Using the cook top burners	19
Burner control knobs	19
Selecting a burner	20
Turning on a burner	20
Using the oven	21
Tips for baking	21
Baking times	21
Tips for baking cakes	21
Tips for baking pastry	21
Tips for cooking vegetables	21
Oven control knob	22
Turning on the oven	22
Adjusting the oven rack	23
Service	24
Cleaning and maintenance	25
Removing the cook top grate	25
Cleaning the cook top burners	25

Cleaning the control panel	25
Cleaning the oven	25
Removing the storage drawer	26
Disassembling range parts 2	8
Disassembling the cook top burners	28
Accessing the pilot light and oven burner	29
Removing and reinstalling the oven door	31
Troubleshooting	32
Cook top	32
Oven	33
Specifications	34
ONE-YEAR LIMITED WARRANTY	35

Introduction

Congratulations on your purchase of a high-quality Insignia product. Your NS-RNG24SS9 represents the state of the art in RV range design and is designed for reliable and trouble-free performance.

IMPORTANT SAFETY INSTRUCTIONS

WARNING If the information in this manual is not followed exactly, a fire or explosion may result causing property damages, personal injury or death.

- Do not store or use gasoline or other flammable vapors and liquids in the vicinity of this or any other appliance.
- **WHAT TO DO IF YOU SMELL GAS.**
 - Extinguish any open flame.
 - Do not try to light any appliance.
 - Do not touch any electrical switch.
 - Do not use any phone in your building.
 - Immediately call your gas supplier from a neighbor's phone. Follow the gas supplier's instructions.
 - If you cannot reach your gas supplier, call the Fire Department.
- Installation and service must be performed by a qualified installer, service agency or gas supplier.

IMPORTANT SAFETY NOTICE

Gas appliances can cause minor exposure to four of these substances, namely benzene, carbon monoxide, formaldehyde, and soot, caused primarily by the incomplete combustion of LP fuels. Properly adjusted burners, indicated by a bluish rather than a yellow flame, will minimize incomplete combustion. Exposure to these substances can also be minimized by venting with an open window or using a ventilation fan or hood.



WARNING

To reduce the risk of the appliance tipping, it must be secured by a properly installed anti-tip device. To check if this device is installed properly, remove the storage drawer to inspect the anti-tip bracket or grasp the top rear edge of the range and carefully attempt to tilt it forward to make sure the range is properly anchored. For instructions, see [Installing the anti-tip device](#) on page 12.

INSIGNIA™

3.7 Cu. Ft. Free-Standing Gas Range for RVs

 **WARNING**

- **ALL RANGES CAN TIP**
- **INJURY TO PERSONS COULD RESULT**
- **INSTALL ANTI-TIP DEVICE PACKED WITH RANGE**
- **SEE INSTALLATION INSTRUCTIONS**

 **WARNING**

Improper installation, adjustment, alteration, service or maintenance can cause injury or property damage. Refer to this manual. For assistance or additional information consult a qualified installer, service agency, manufacturer (dealer) or the gas supplier.

 **WARNING**

To avoid the possibility of electrical shock, disconnect the power supply before servicing this unit.

 **WARNING**

NEVER cover any slots, holes or passages in the oven bottom or cover an entire rack with materials such as aluminum foil. Doing so blocks air flow through the oven and may cause carbon monoxide poisoning. Aluminum foil linings may also trap heat, causing a fire hazard.

 **WARNING**

NEVER use this appliance as a space heater to heat or warm the room. Doing so may result in carbon monoxide and overheating of the oven.

GENERAL SAFETY PRECAUTIONS **WARNING****READ ALL INSTRUCTIONS BEFORE USING THIS APPLIANCE****1 CAREFUL THOUGHT SHOULD BE GIVEN TO THE LOCATION OF THE RANGE.**

Avoid placement in these areas: in a main "traffic path"; in an isolated area with no counter space nearby; where open range doors could create a hazard; in a drafty location which could cause the pilot to blow out.

2 KEEP CHILDREN AND PETS AWAY FROM THE RANGE.

Children should not play with the range controls. Range surfaces are hot. The range should not be used as a step stool to the cabinet above.

3 FOR SAFETY REASONS, DO NOT USE THE RANGE AS A KITCHEN HEATER. Ovens and top burners are not designed for heating use.

- 4 BE SURE THE RANGE IS PROPERLY INSTALLED AND GROUNDED BY A QUALIFIED TECHNICIAN. BE SURE YOUR RANGE IS CORRECTLY ADJUSTED BY A QUALIFIED SERVICE TECHNICIAN OR INSTALLER FOR THE TYPE OF PROPANE GAS ON WHICH IT IS TO BE USED. SEE INSTALLATION INSTRUCTIONS.**
- 5 NEVER INSTALL RANGE OVER KITCHEN CARPETING.**

Some carpet materials are highly flammable and some absorb grease which could be a fire hazard.
- 6 REMEMBER FABRIC IS FLAMMABLE.**

Long flowing sleeves have no place in a kitchen. Don't lean on a range. If the range is near a window, use an appropriate window treatment.
- 7 IF THE PILOT GOES OUT, YOU SHOULD DETECT A FAINT GAS ODOR AS YOUR SIGNAL TO RELIGHT THE PILOT.**

As a safety measure, open a window or door to ventilate the room before relighting the pilot. If the range connections are not perfectly tight, you can have a small leak and therefore a faint gas odor. NEVER use a match or other flame to locate such a leak. Use a liquid detergent or thick soap and water solution in the areas where you think the leak might be. If a bubble develops, it indicates a possible leak. Gas supply should be turned off immediately and you should call your gas company and/or service company.
- 8 NEVER LEAVE A BURNER ON AND UNLIT FOR MORE THAN 5 SECONDS.**
- 9 A WARNING: SERIOUS HAZARDS ARE ASSOCIATED WITH REACHING INTO STORAGE CABINETS ABOVE THE RANGE WHEN THE TOP BURNERS AND/OR OVEN ARE IN OPERATION.**

Do not store items that are attractive to children above the range. Do not let clothing come into contact with top burners when range is in operation.
- 10 POSSIBLE HAZARDS OR INJURIES MAY RESULT FROM THE MISUSE OF APPLIANCE DOORS OR DRAWERS** such as stepping, leaning or sitting on the doors or drawers.
- 11 DO NOT USE THE TOP OF THE RANGE OR THE OVEN AS A STORAGE AREA.**

Items stored on the range top can become too hot and melt. Do not store flammable materials in the oven.
- 12 USE A GOOD POTHOLDER WHEN PULLING OUT OVEN RACKS TO ADD OR REMOVE FOOD.**

Dish towels or other substitutes can cause bad burns. Use only dry potholders. Damp or moist potholders on hot surfaces may result in burns from steam. Do not let a potholder touch a flame.
- 13 KEEP ALL PLASTICS AWAY FROM THE RANGE,** as plastics are vulnerable to heat.
- 14 AVOID UNSTABLE, EASILY TIPPED PANS.** Pan handles should be turned to the back or side of the range—not out into the room or over adjacent burners. Only use utensils that are suitable for range and oven use.
- 15 DO NOT HEAT UNOPENED CONTAINERS OF FOOD ON SURFACE BURNERS OR IN THE OVEN.**

Buildup of pressure may cause the container to burst and result in serious personal harm and/or damage to the range.
- 16 ALUMINUM FOIL WHEN USED IMPROPERLY IS A CAUSE OF MANY RANGE PROBLEMS.**

See the oven section of this book for instructions for proper use
- 17 GREASE IS FLAMMABLE AND SHOULD BE HANDLED CAREFULLY.** Avoid letting grease deposits collect around the range or in vent fans. Let quantities of hot fat, a pan of deep fat for example, cool before attempting to move it. If a grease fire should occur in a pan, put out the flame by placing a lid on the pan. DO NOT throw water on a grease fire. Do not turn on the vent hood. Use a dry chemical or foam type fire extinguisher. If a fire should occur in the oven, turn off the oven, close the oven door and allow the food or grease to burn itself out in the oven. If smoke or fire persist, call your local fire department.
- 18 AVOID THE USE OF AEROSOL SPRAYS NEAR A RANGE AS MOST ARE FLAMMABLE.**
- 19 NEVER LEAVE SURFACE BURNERS UNATTENDED AT HIGH OR MEDIUM FLAME SETTINGS.**

Adjust top burner flame size so it does not extend beyond the edge of the cookware. Excessive flame is hazardous
- 20 DO NOT USE A RANGE THAT IS IN NEED OF REPAIR.** Repairs should be done by a qualified person. Poorly done repairs could result in a safety hazard. Do not replace or repair any part of the range yourself unless it is recommended in this book.
- 21 DO NOT TOUCH THE INTERIOR SURFACES OF THE OVEN DURING OR IMMEDIATELY AFTER USE.** Do not let clothing or other flammable materials contact burners. Although these surfaces may be dark in color they can still be hot enough to burn. Other areas of the range can become hot enough to cause burns, such as vent openings, main top, window, oven door, and oven racks.
- 22 DO NOT OBSTRUCT THE FLOW OF COMBUSTION OR VENTILATION AIR.**
- 23 BE SURE ALL PACKING MATERIALS ARE REMOVED FROM THE RANGE** before operating it to prevent fire or smoke damage should the packing material ignite.
- 24 LEAK TESTING OF THE APPLIANCE SHALL BE CONDUCTED ACCORDING TO THE MANUFACTURER'S INSTRUCTIONS.**

INSIGNIA™

3.7 Cu. Ft. Free-Standing Gas Range for RVs

Installation instructions

- The installation must conform with local codes or, in the absence of local codes, with the national Fuel Gas Code, ANSI Z223.1/NFPA 54 or, in Canada the Propane Gas Installation Code, CSA B149.1.
- The installation of appliances designed for manufactured (mobile) home installation must conform with the Manufactured Home Construction and Safety Standard, Title 24 CFR, Part 3280 (formerly the Federal Standard for Mobile Home Construction and Safety, Title 24, HUD (part 280)).
- The installation of appliances designed for recreational park trailers must conform with state codes, with the standard for Recreational Park Trailers, ANSI A119.5.
- The installation must conform with state or other codes or, in the absence of such codes, with the Standard for Recreational Vehicles, ANSI/NFPA 1192.
- When installed, the range must be electrically grounded in accordance with local codes.
- The range and its individual shut-off valve must be disconnected from the gas supply piping system during any pressure testing of that system at test pressures in excess of 1/2 psi (3.5 k Pa).
- The range must be isolated from the gas supply piping system by closing its individual manual shut-off valve during any pressure testing of the gas supply piping system at test pressures equal to or less than 1/2 psi (3.5 k Pa).
- The maximum gas supply pressure must be in accordance with the manifold 10" WC inlet pressure rating of the gas appliance pressure regulator supplied.
- The gas supply pressure for checking the regulator setting must be at least 1" WC (249 Pa) above the manufacturer's specified manifold pressure. Any opening in the wall behind the range and in the floor under the range must be sealed.

SAVE THESE INSTRUCTIONS

Features

Package contents

- 3.7 Cu. Ft. Free-Standing Gas Range for RV
- Anti-tip device
- Plastic pad kit
- *User Guide*

Main components

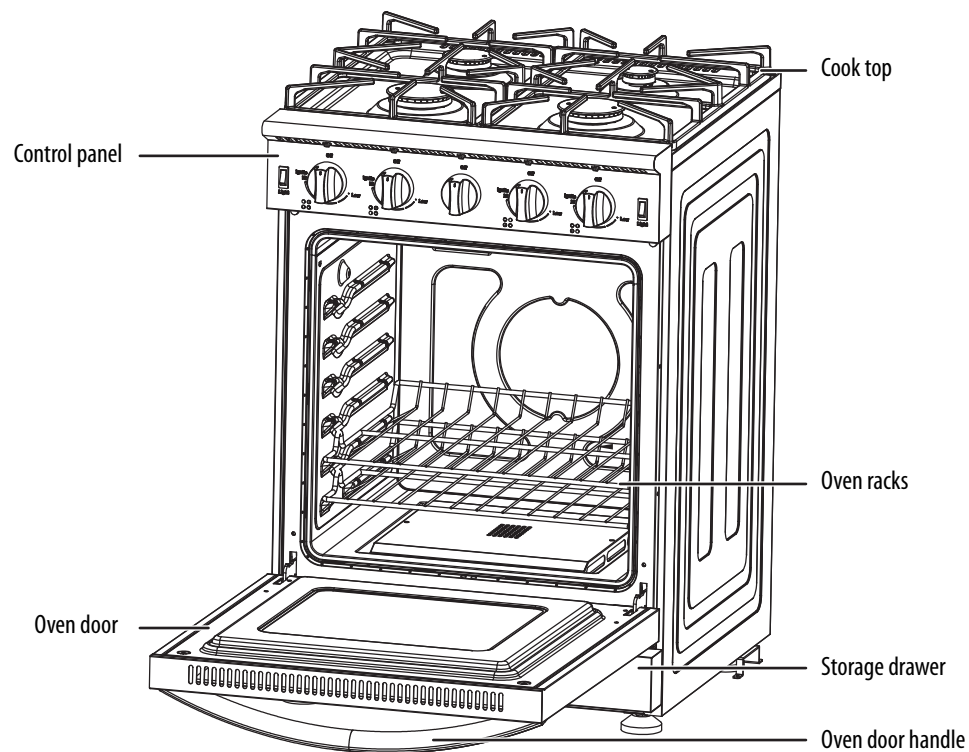

Control panel

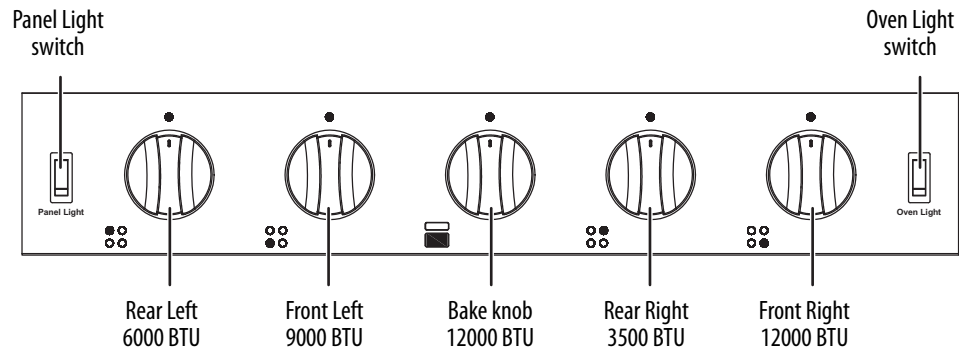

Range dimensions

Front

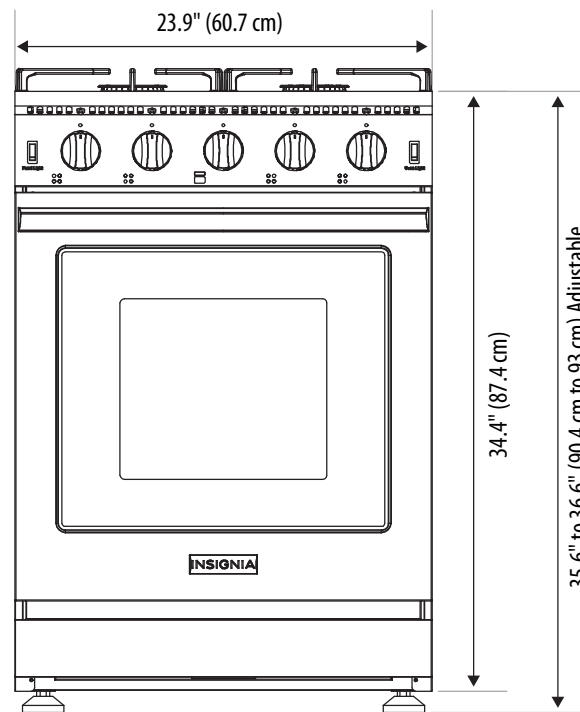

INSIGNIA™

3.7 Cu. Ft. Free-Standing Gas Range for RVs

Side

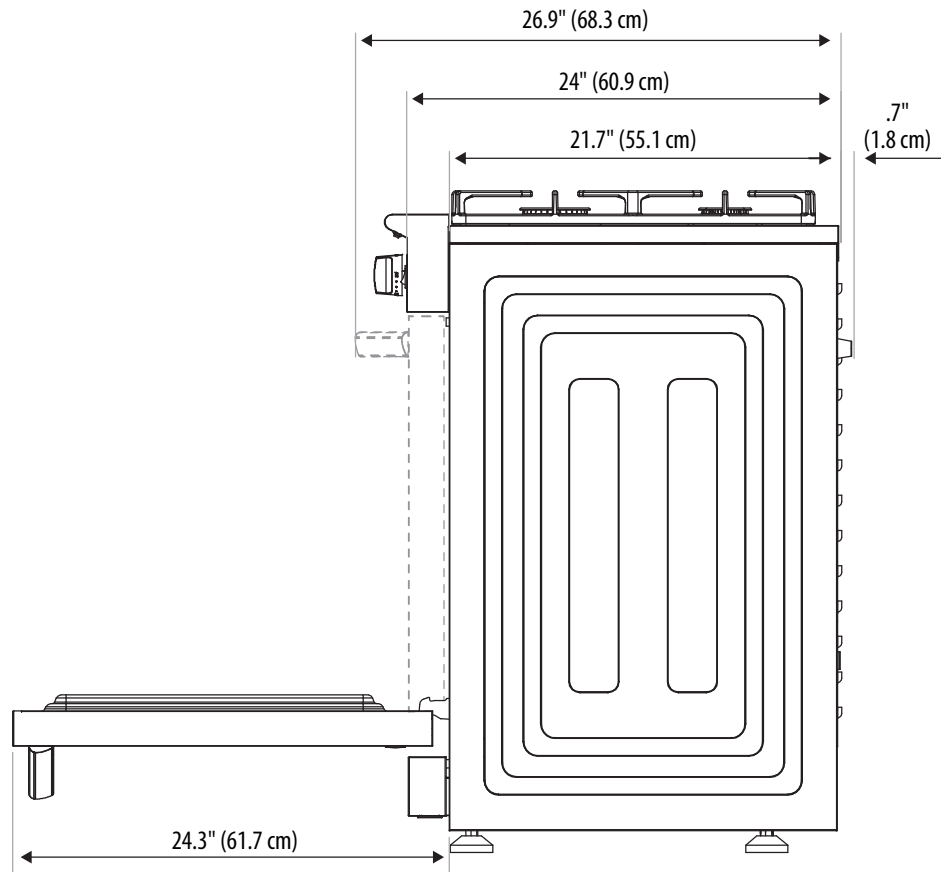

Installation

3.7 Cu. Ft. Free-Standing Gas Range for RVs

Installing the range	10
Clearances and dimensions	10
Important notes to the installer:.....	11
Before installing the range	11
Adjusting the height and leveling the range .	11
Installing the anti-tip device.....	12
Connecting to gas	14
Installing plastic pads to the oven back.....	15
Connecting to power	16
Testing for gas leaks.....	16
Testing top burners	17
Testing the oven burner.....	17

INSIGNIA™

Installing the range

IMPORTANT: We recommend that a professional installer install your range.

If your range is not installed correctly, incorrect electrical grounding or gas leaks can cause a fire or explosion which can lead to injury or death.

CAUTION Material damage:

- Do not use the door or handle to lift or move the range.
- The range must be placed directly on a floor with 1/8" (3 mm) thick commercial grade vinyl composition floor finishing materials. Do not place the range on to a base or pedestal.

Clearances and dimensions

Use the dimensions shown below to install the range. The back and sides of the range below the cook top can be flush to combustible material.

A minimum clearance of 18 in. (45.7 cm) vertically is required between any combustible construction adjacent to the countertop. A minimum clearance of 30 in. (76 cm) is required between the top cooking grate and any combustible material directly above the cooking surface. Make sure that the drip pan is parallel to countertop. Adjust the range feet, if necessary.

Note: The measurements in the following graphic are minimum requirements.

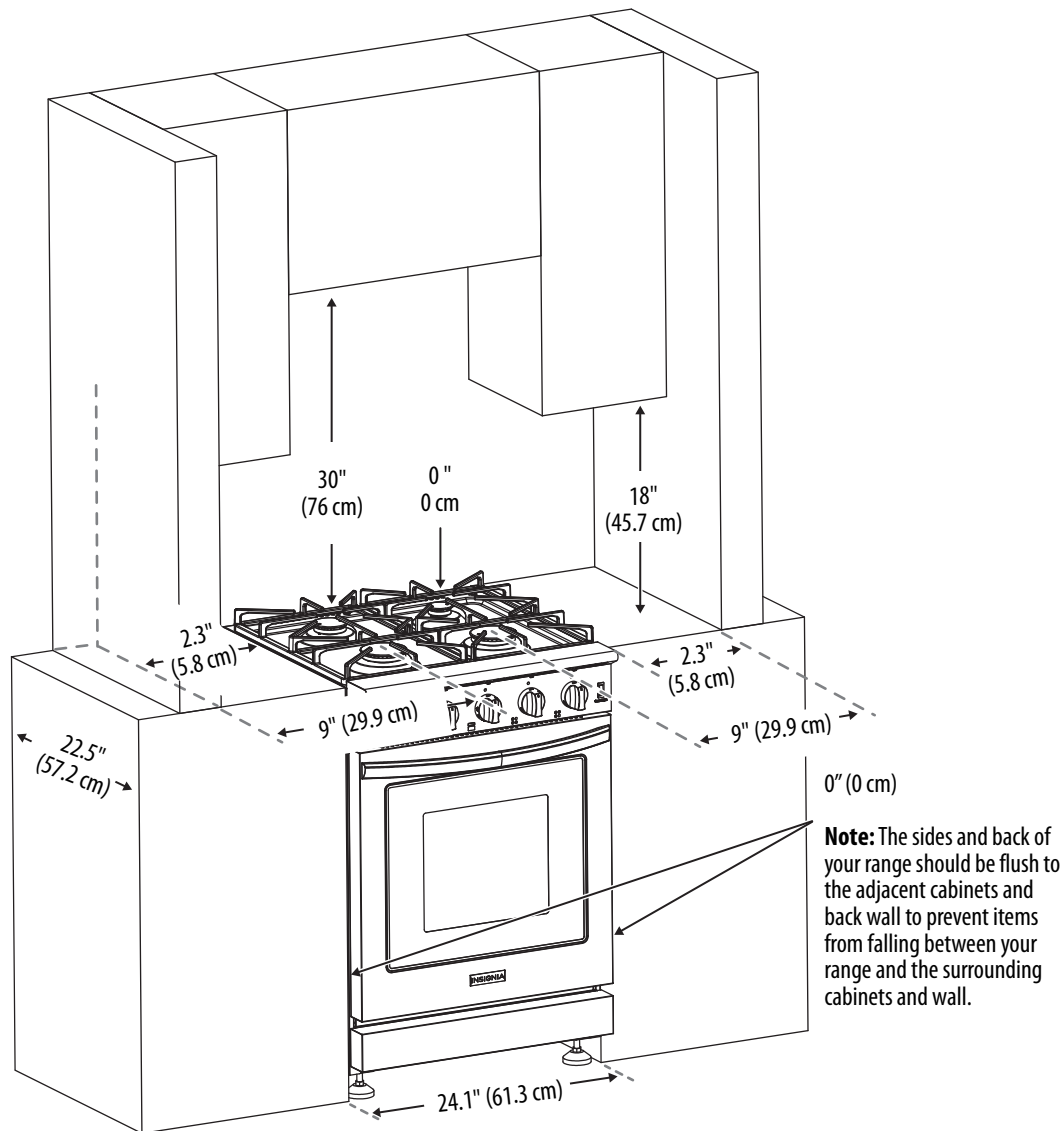

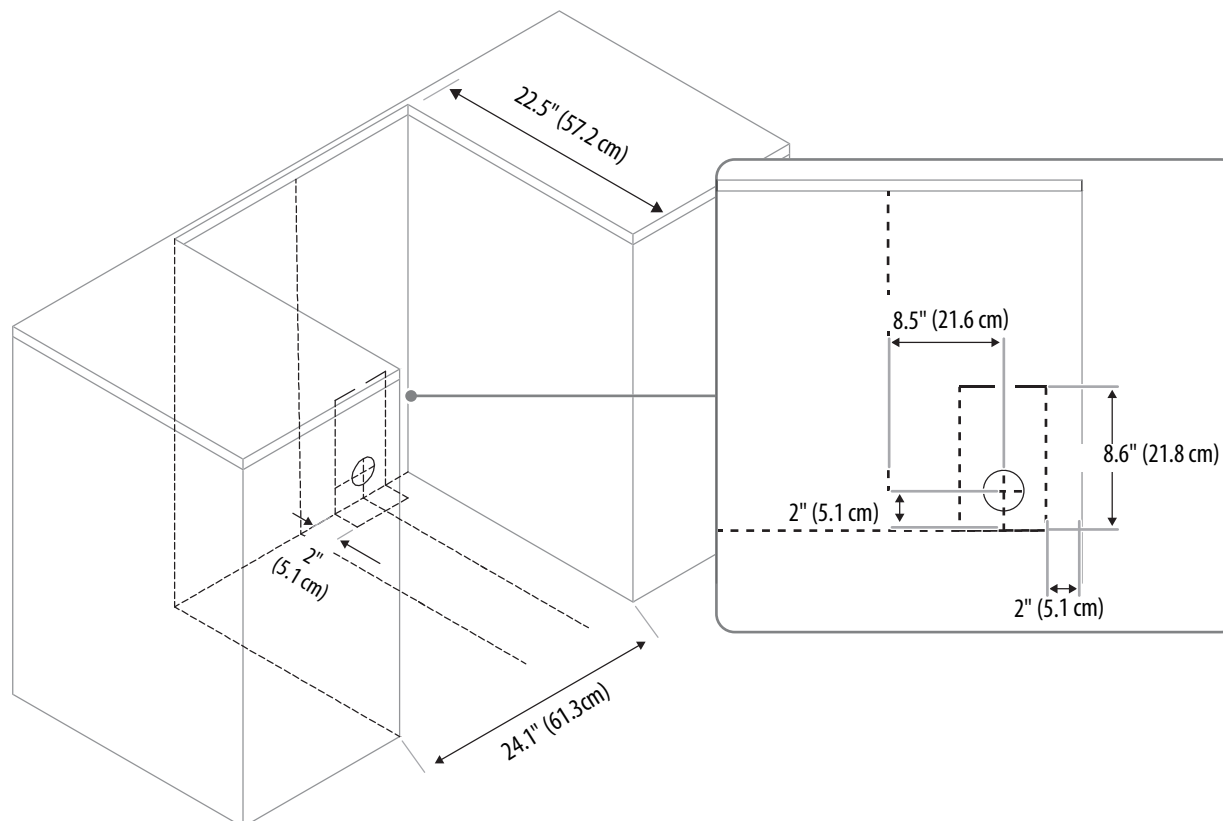
Gas and electric location requirements**Important notes to the installer:**

- 1 Read this manual before installing the range.
- 2 Observe all governing codes and ordinances.
- 3 Make sure that you leave these instructions with the range.
- 4 Before installing the range in an area covered with linoleum or any synthetic floor covering, make sure that the floor covering can withstand temperatures at least 90°F (32°C) above room temperature without shrinking, warping, or discoloring.
- 5 Do not install the range over carpeting unless you place an insulating pad or sheet of 1/4-in. (.64 cm) thick plywood between the range and carpeting.

Before installing the range

- Remove the exterior and interior packing.
- Wipe the surfaces of the range with a damp cloth or sponge, then wipe them dry with a clean, dry cloth.

Adjusting the height and leveling the range

The range should be the same height as the adjacent countertops or workspaces. The range should also be level. If the range is not level, the door may not close or seal correctly which can cause uneven heating and gas wastage problems.

- To adjust the height and level the range, turn the feet clockwise (to raise) the range or counter-clockwise (to lower).

Note: To make it easier to adjust the feet, have someone push against the top of the range to tilt it slightly.

INSIGNIA™

3.7 Cu. Ft. Free-Standing Gas Range for RVs

Installing the anti-tip device**WARNING:**

- All ranges can tip and injure people. Install the anti-tip device that came with the range.
- If you pull the range away from the wall for cleaning, service, or any other reason, make sure that the anti-tip device is correctly re-engaged when you push the range back against the wall. In the event of abnormal usage (such as a person standing, sitting, or leaning on an open door), failure to take this precaution can result in tipping of the range. Personal injury might result from spilled hot liquids or from the range itself.

- 1 Adjust the range feet to the correct height. Make sure that the range is level. See [Adjusting the height and leveling the range](#) on page 11.
- 2 Position the rear brackets on the floor with the notches on the brackets facing the front of the range, then screw the brackets to the floor using four of the provided screws per bracket.

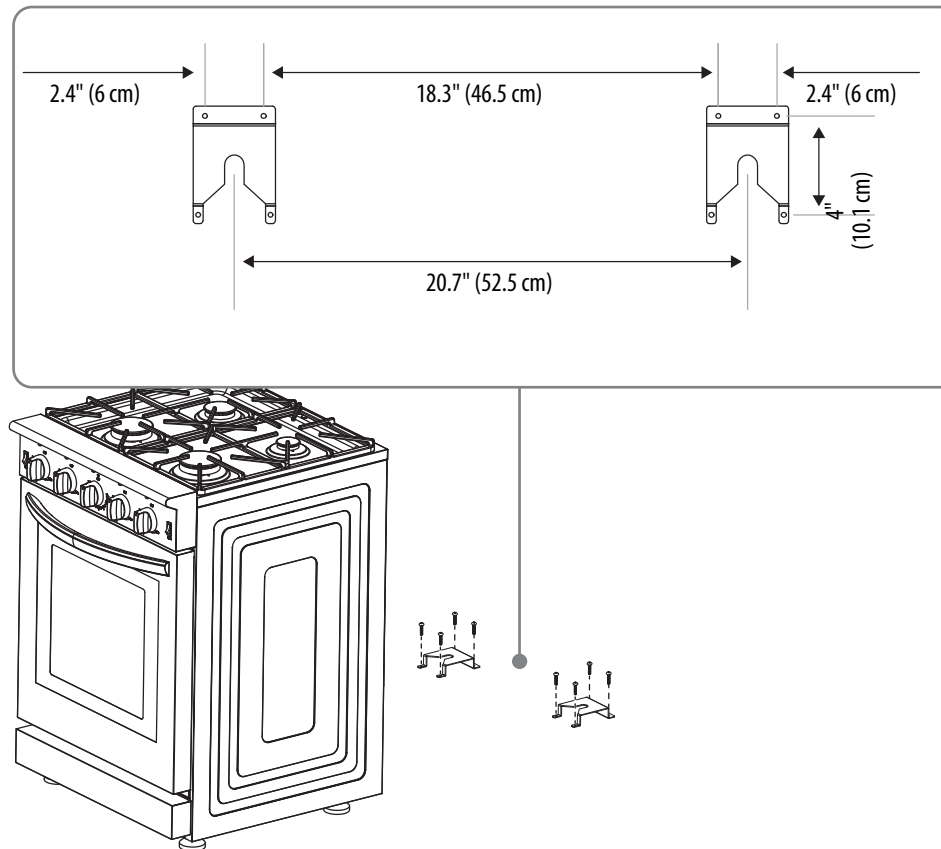

- 3** Align the rear feet with the notches on the rear brackets, then slide the range into place. Make sure that the rear feet are under the brackets.

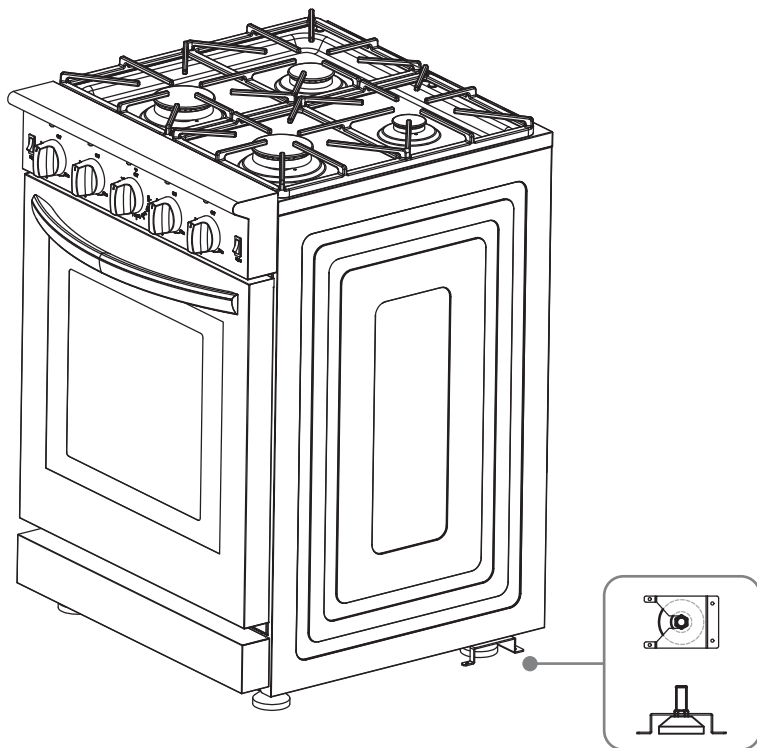

- 4** Open the storage drawer, slide the notches on the front brackets over the front feet, then screw the brackets into the floor using two of the provided screws for each bracket.

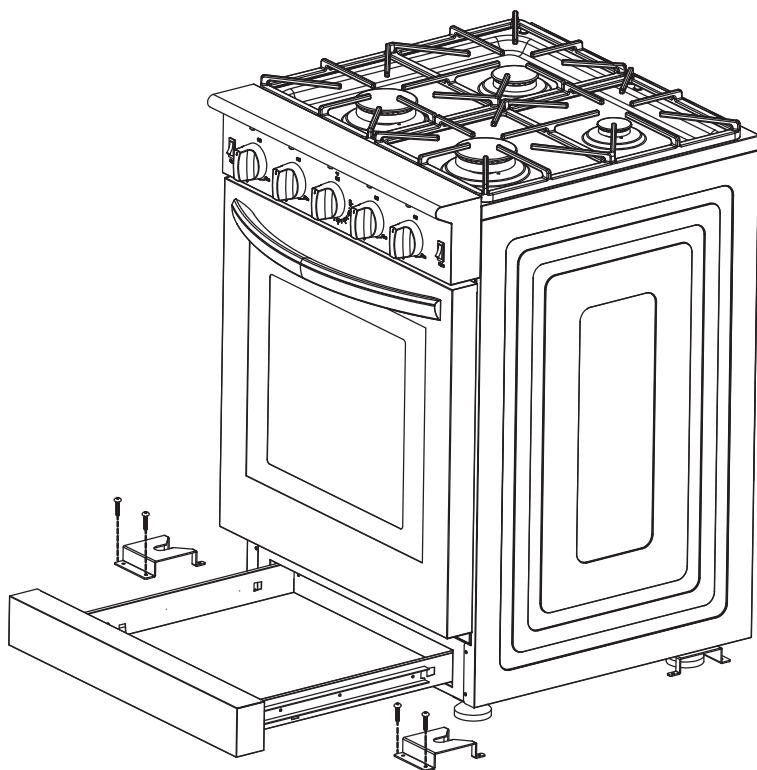

INSIGNIA™

3.7 Cu. Ft. Free-Standing Gas Range for RVs

5 Close the drawer.

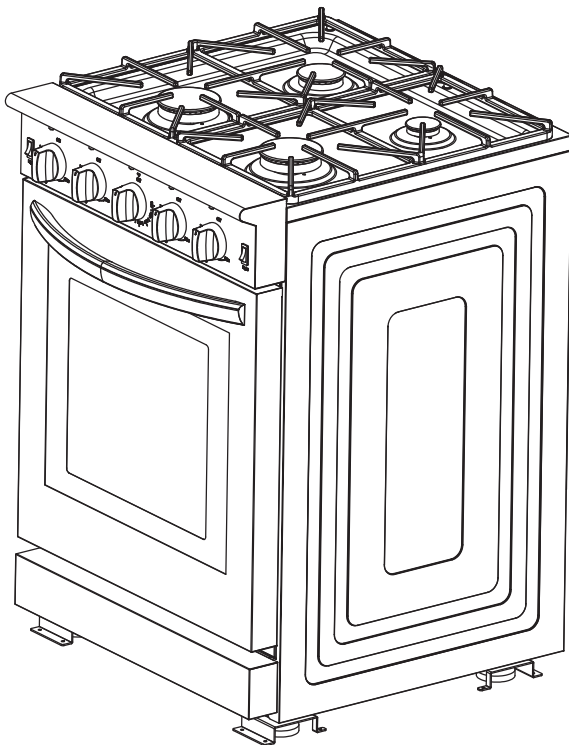

Connecting to gas

WARNING: If your range is not installed correctly, gas leaks can cause a fire or explosion which can lead to death or injury.
We recommend that a professional installer connect the gas.

CAUTION: Your range can use only Propane gas. Do not connect it to any other type gas.

You can connect the gas using a flexible connector or a rigid pipe.

Flexible connector method

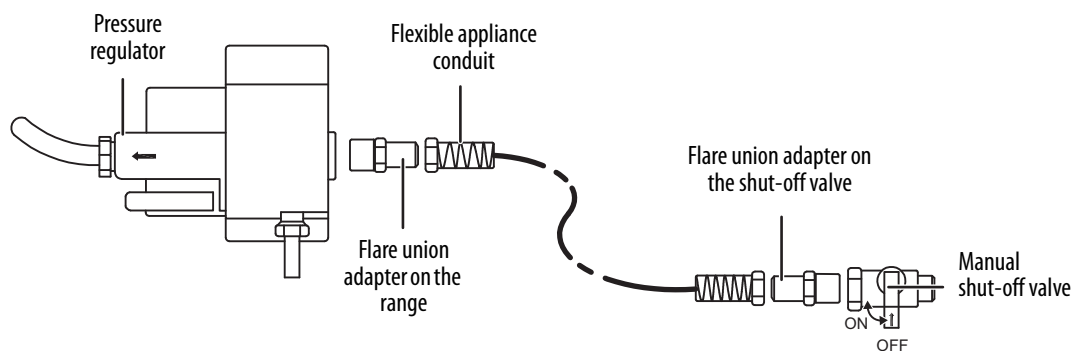

- 1 Install a male 1/2" flare adapter at the 1/2" NPT internal thread in the range inlet. Use a backup wrench on the elbow fitting to avoid damage.
- 2 Install a male 1/2" or 3/4" flare union adapter in the NPT internal thread on the manual shut-off valve.
- 3 Connect the flexible metal appliance connector.
- 4 Make sure that the circuit breaker is off, then plug the power cord into the electrical outlet. Do not turn the circuit breaker back on.
- 5 Push the range back into position making sure that the rear legs slide under the anti-tip brackets. The range sits 3/4" (19 mm) away from the wall when correctly installed.

CAUTION: Be careful not to crimp the flexible connector.

- 6 Carefully tip the range forward to make sure that the front legs are under the anti-tip brackets.

Rigid pipe method

The configuration of the rigid pipe connection varies depending on the location of the gas pipe stub.

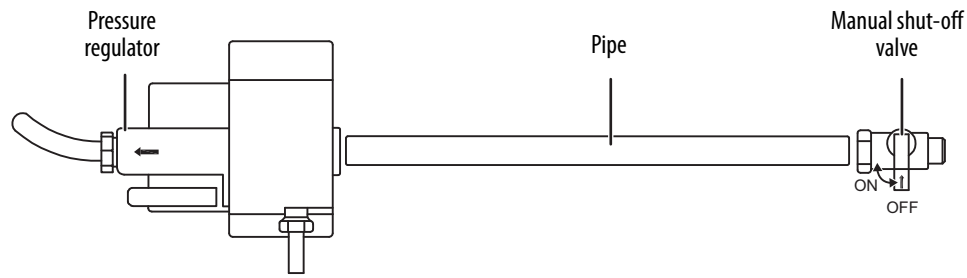

- 1 Make sure that the circuit breaker is off, then plug the power cord into the electrical outlet. Do not turn the circuit breaker back on.
- 2 Push the range back into position making sure that the rear legs slide under the anti-tip brackets. The range sits 3/4" (19 mm) away from the wall when correctly installed.
- 3 Carefully tip the range forward to make sure that the front legs are under the anti-tip brackets.
- 4 Connect the pipe to the range at the union. Access the connection through the access panel behind the storage drawer.

Installing plastic pads to the oven back

To prevent the range from getting too close to the wall behind the range, install the included plastic pads.

- 1 Locate the plastic pad kit. It includes:

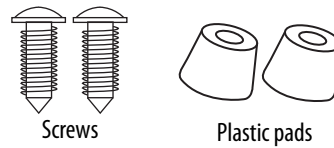

- 2 Align the holes in the plastic pads with the holes on the top, back of the range, then secure the pads to the range with the provided screws.

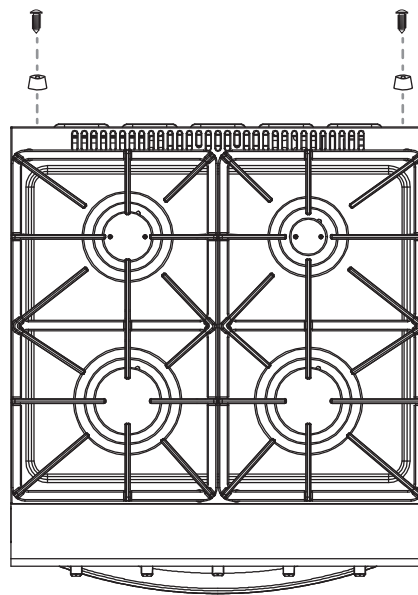

INSIGNIA™

3.7 Cu. Ft. Free-Standing Gas Range for RVs

Connecting to power

DANGER: Risk of electric shock, short circuit, or fire if the power cord is damaged.

The power cord must not be clamped, bent, or trapped or come into contact with hot parts of the range. If the power cord is damaged, it must be replaced by a qualified electrician.

IMPORTANT:

- Electrical installation should comply with national and local codes. The range must be grounded.
- The range requires a 110/120VAC electrical supply to operate the electronic ignition system. The 5 ft. (1.5 m) power cord provided with the range is equipped with a 3-prong, grounded plug for protection against shock hazard.
- The power outlet should have its own 15 amp circuit breaker.
- In addition, be aware of local codes and ordinances when installing your services.
- The wiring diagram covering the control circuit is located on the back of the range. The power supply data must correspond to the data specified on the rating plate of the range. The rating plate sticker is on the power cord.

WARNINGS: Avoid fire hazard or electrical shock.

- Do not use an adapter plug, an extension cord, or remove the grounding prong from the power cord. Failure to follow this warning can cause serious injury, fire, or death.
- The range is equipped with a 3-prong grounding plug for your protection against shock hazard and should be plugged directly into a correctly grounded receptacle. DO NOT cut or remove the grounding prong from this plug.
- The power cord must be plugged into a mating 3-prong ground-type outlet, grounded to conform with the National Electrical Code, ANSI/NFPA 70 latest edition, or Canadian Electrical Code (CSA) and all local codes and ordinances.
- For personal safety, the range must be correctly grounded. For maximum safety, the power cord must be plugged into an electrical outlet that is correctly polarized and grounded.
- If a 2-prong wall receptacle is the only available outlet, have it replaced with a correctly grounded 3-prong wall receptacle installed by a qualified electrician.
- Do not ground to a gas pipe.

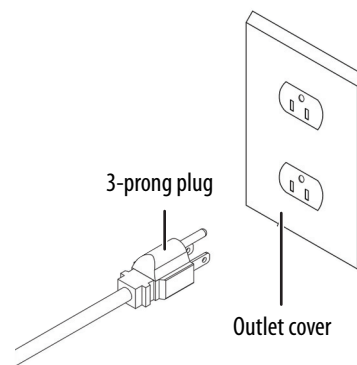

Testing for gas leaks

- 1 Make sure that the circuit breaker is turned off.
- 2 Turn on the gas.
- 3 Apply a non-corrosive leak detection fluid to all joints and fittings in the gas connection between the shut-off valve and the range. Include gas fittings and joints in the range if connections may have been disturbed during installation.
- 4 If bubbles appear around fittings and connections, turn off the supply line gas shut-off valve, then tighten the connections.
- 5 Retest for leaks. The leak check is complete when no bubbles appear.

CAUTION: Never check for leaks with a flame. Do not continue to the next step until all leaks are eliminated. Before you plug in an electrical cord, make sure that all controls are in the OFF position.

- 6 Wipe off all detection fluid residue.
- 7 Turn on the circuit breaker.

Testing top burners

- 1 Test the burner ignition.
Push in on a burner knob, then turn it counter-clockwise to the flame symbol. The igniter/spark module produces a clicking sound. After the air has been purged from the supply lines, the burner should light within six seconds.
- 2 Test the high flame setting.
Turn a burner on to **HI**. The flame may burn yellow for a few seconds, then it should turn blue. If the burner continues to burn mostly or completely yellow, see [Burner flames are unusually large and yellow](#) on page 32 or contact a qualified service technician.
- 3 Test the low flame setting.
Turn a burner on to **LOW**. Make sure that the flame completely surrounds the burner. There should be a flame at the burner port and no air gap between the flame and the burner. If the burner does not carry over, see [Flames do not burn all around the burner cap](#) on page 32 or contact a qualified service technician.
- 4 Repeat these steps to test each burner.

Testing the oven burner

Note: You can see the flame through the holes in the bottom of the oven.

- 1 Test the bake burner ignition.
Push in and turn the oven control knob to the flame symbol. Do not release the knob. The electrode clicks and the pilot burner ignites. You can see the pilot flame through the holes on the bottom of the oven.
Keep pushing the control knob on the flame symbol position for 5 to 10 seconds until the flame is lit and stable. Depending on the length of the gas pipe, you may need to keep pushing for one to three minutes until the gas pushes the air out of the pipe.
- 2 Test the bake burner flame.
While the pilot burner is lit and the flame is stable, turn the control knob counter-clockwise to each temperature and inspect the flame. If the flame is completely or mostly yellow, make sure that the regulator is set for the correct fuel, then retest.

Note: Some yellow streaking is normal during initial start-up. Let the oven operate for four to five minutes, then re-evaluate before making adjustments. If the flame is still yellow, contact a qualified service technician.

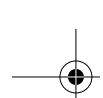

Using

3.7 Cu. Ft. Free-Standing Gas Range for RVs

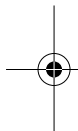

Before you begin using your range	19
Using the cook top burners	19
Tips for saving gas	19
Burner control knobs	19
Selecting a burner	20
Turning on a burner	20
Using the oven	21
Tips for baking	21
Baking times	21
Tips for baking cakes	21
Tips for baking cakes	21
Tips for baking pastry	21
Tips for cooking vegetables	21
Oven control knob	22
Turning on the oven	22
Adjusting the oven rack	23

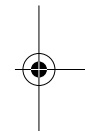

Before you begin using your range

Before turning on the burners or oven:

- Remove all packaging materials.
- Wipe the surfaces of your range with a damp cloth or sponge, then dry with a clean, dry cloth.

CAUTION: Do not use harsh detergents, scouring powder, or any sharp objects to clean your range. These items can damage the surfaces of the range.

When you turn on a burner or the oven for the first time, smoke and odors may be emitted. This is normal. Make sure that the room is well ventilated.

WARNINGS: Hot surfaces may cause burns.

- Do not touch any hot surface on your range. Use oven gloves or potholders.
- Do not let children near your range.

Tips for saving gas

- Use dark-colored or enamel-coated cookware in the oven because the heat transmission is better.
- Before cooking, preheat the oven if the recipe calls for preheating.
- Do not open the oven door during cooking.
- Try to cook more than one dish in the oven at the same time whenever possible.
- If you plan to cook more than one dish, cook them one after another. The oven will already be hot.
- Defrost frozen dishes before cooking them.
- Use pots and pans with covers for cooking.
- Select the burner that most closely matches the size of the bottom of the pot you are using. Always select the correct pot size for your dishes. Larger pots require more gas.

Using the cook top burners

WARNING: Overheated oil can catch on fire.

When you are heating oil, do not leave it unattended. If oil overheats, it may catch on fire. If oil catches on fire, do not try to extinguish the fire with water. Instead, immediately cover the pot or pan with a lid. If you can safely reach the burner control knob, turn off the burner. Call the fire department if this does not extinguish the fire.

- Before frying foods, always dry them well, then place them gently into the hot oil.
- Make sure that frozen foods are completely thawed before frying.
- Do not cover a pot or pan you are using to heat oil.
- Do not place empty pots or pans on burners that are switched on. The pots or pans could be damaged.
- Operating a burner without a pot or pan on it will damage your range.
- Turn off burners after cooking is complete.
- When using burners, the cook top can be hot. Do not put plastic or aluminum items on it.
- Use flat-bottomed pots and pans only.
- Put an appropriate amount of food in pots and pans. An overfilled pot or pan can overflow and make cleanup harder.
- Do not put pot or pan lids on a burner.
- Place the pot or pan in the center of the burner.
- When you want to move a pot or pan onto another burner, lift it up and place it on the other burner. Do not slide a pot or pan from one burner to another.

Burner control knobs

Each burner has a separate control knob.

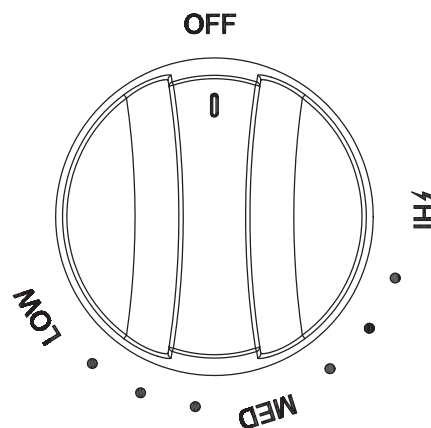

INSIGNIA™

3.7 Cu. Ft. Free-Standing Gas Range for RVs

Selecting a burner

WARNING: Never let the flame extend beyond the outer edge of the cooking pot or pan. A higher flame wastes energy and increases your risk of being burned by the flame.

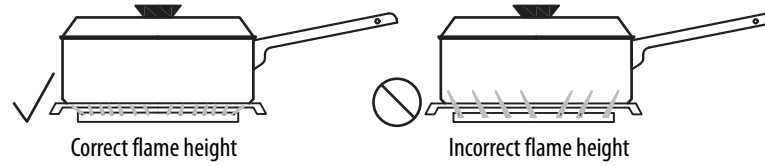

The size of a pot or pan and the burner flame must match each other. Adjust the flame so that it does not extend beyond the bottom of the pot or pan, and center the pot or pan over the burner.

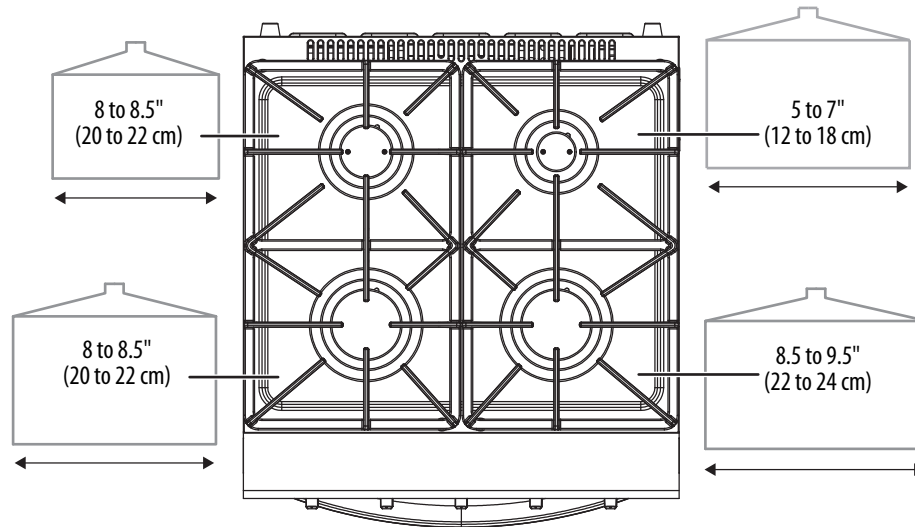

- Normal burner (mid-size): 8 to 8.5" (20 to 22 cm) back left
- Auxiliary burner (small): 5 - 7" (12-18 cm) back right
- Normal burner (mid-size): 8 to 8.5" (20 to 22 cm) front left
- Rapid burner (large): 8.5 - 9.5" (22-24 cm) front right

Turning on a burner

Note: The large flame symbol on a burner knob indicates the highest cooking power.

- 1 While pressing in on a burner control knob, turn it counter-clockwise to the large flame symbol. Your range generates an ignition spark and ignites the gas.

Note: If there is no electricity, you can ignite the gas with a match.

- 2 After the gas is ignited, release the knob.
- 3 Turn the knob to adjust the flame.
- 4 When cooking is complete, turn the knob to the **OFF** position.

WARNING: Risk of explosion if gas does not ignite.

Do not press a burner knob for longer than 15 seconds if the gas does not ignite. Release the knob and wait for one minute, then repeat the ignition process.

Using the oven

WARNING: Risk of scalding by hot steam.

Stand away from the oven when opening the oven door. Escaping hot air or steam can burn your hands, face, or eyes. Let hot air or steam escape before removing or replacing food.

Tips for baking

- Use appropriate non-stick coated metal sheets or aluminum containers or use heat-resistant silicone molds.
- Make the best use of the space on the rack. We recommend placing the baking pan in the middle of the rack.
- Select the correct shelf position before turning the oven on.
- Do not move oven shelves when hot. If you must move a rack while the oven is hot, do not let the potholder contact the hot oven burner.
- Keep the oven door closed as much as possible.

Baking times

FOOD	PREPARATION	BAKING TIME (Depending on thickness)
Toasting of bread products	NA	10 - 15 min.
Small cuts of meat, sausages, bacon, and similar types	NA	15 - 20 min.
Chops, ham steaks, chicken pieces	Chicken placed in the bottom of a broiling pan or deep baking dish.	20 - 25 min.
Whole fish, fish fillets, fish fingers	Whole fish and fish fillets placed in the base of a broiling pan.	15 - 20 min.
Fish in breadcrumbs	NA	15 - 20 min.
Precooked potato products	NA	15 - 20 min.
Pizza	Placed in the base of a broiling pan.	20 - 25 min.
Grilling/browning of food	Food placed directly on the base of a roasting pan. Heat the oven to 450 to 500°F.	8 - 10 min.

Tips for baking cakes

- If a cake is too dry, the next time you bake a cake, increase the temperature by 25°F and reduce the cooking time.
- If a cake falls, the next time you bake a cake, use less liquid or lower the temperature by 25°F.
- If a cake is too dark on top, the next time you bake a cake, place it on a lower rack, lower the temperature, and increase the cooking time.
- If a cake is done on the inside but sticky on the outside, the next time you bake a cake, use less liquid, lower the temperature, and increase the cooking time.

Tips for baking pastry

- If the pastry is too dry, the next time you bake pastry:
 - Increase the temperature by 25°F and decrease the cooking time
 - Dampen the layers of dough with a mixture made of milk and egg
- If the pastry takes too long to bake, the next time you bake pastry, make sure that the thickness of the pastry does not exceed the depth of the baking tray.
- If the upper side of the pastry gets brown but the lower part is not cooked, the next time you bake pastry:
 - Make sure that you have not used too much moistening liquid at the bottom of the pastry
 - Try placing the pastry on a lower shelf.

Tips for cooking vegetables

- If the vegetables get too dry, the next time you bake vegetables, cook them in a covered dish rather than a tray.
- If a vegetable does not seem to cook, the next time you bake this vegetable, parboil or steam the vegetable before baking.

INSIGNIA™

3.7 Cu. Ft. Free-Standing Gas Range for RVs

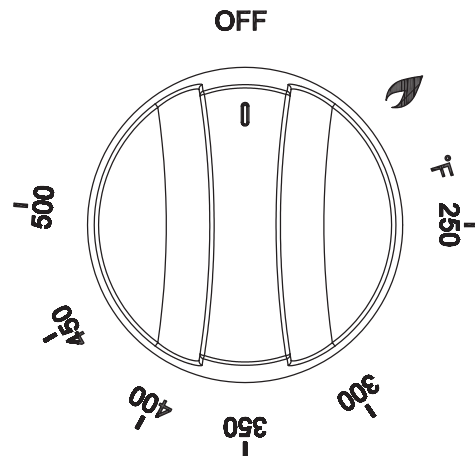
Oven control knob**Turning on the oven****WARNING:**

Do not try to light the oven with a match or lighter.

- 1 Close the oven door.
- 2 While pressing in on the oven control knob, turn it counter-clockwise to the large flame symbol. Your range generates an ignition spark and ignites the gas.
- 3 Keep the knob depressed for another 5 to 10 seconds.
- 4 Look for a flame through the holes in the bottom of the oven to make sure that the gas has ignited.
- 5 Release the knob, then turn it to select a temperature setting.
- 6 When cooking is complete, turn the knob to the **OFF** position.

WARNING: Risk of explosion if gas does not ignite.

Do not press the oven control knob for longer than 60 seconds if the gas does not ignite. Release the knob and wait for one minute, then repeat the ignition process.

Adjusting the oven rack

Note: The maximum load for an oven rack is 22 lbs (10 kg).

The oven racks slide into rails in the inside of the oven. The rails have a stop position so you do not accidentally pull a rack completely out when you add or remove a backing dish.

- 1 Pull the rack toward you until it reaches the stop position, then tilt up the front edge of the rack and pull it completely out.

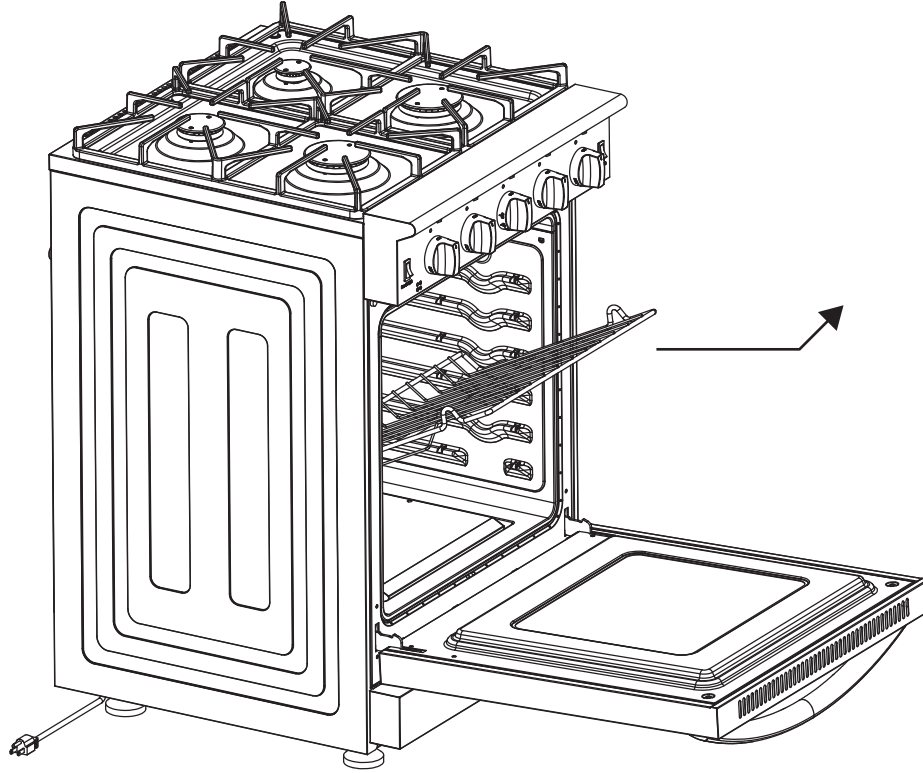

- 2 With the rack tilted up, align it with the new rails, then slide the rack over the stop position.
- 3 Lower the rack, then push it all the way into the oven.

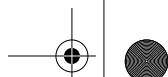

INSIGNIA™

3.7 Cu. Ft. Free-Standing Gas Range for RVs



Service

3.7 Cu. Ft. Free-Standing Gas Range for RVs



- Cleaning and maintenance..... 25
- Removing the cook top grate 25
- Cleaning the cook top burners 25
- Cleaning the control panel 25
- Cleaning the oven 25
- Removing the storage drawer 26
- Disassembling the cook top burners..... 28
- Accessing the pilot light and oven burner ... 29
- Removing and reinstalling the oven door.... 31



Cleaning and maintenance

Removing the cook top grate

- Use both hands, one on each side of the grate, or one hand in the middle of the grate to pull the grate straight up and off the cook top.

CAUTION: The grate has a fixed metal rod through the middle of the grate. If you pull the grate off at an angle, the rod may bend and break.

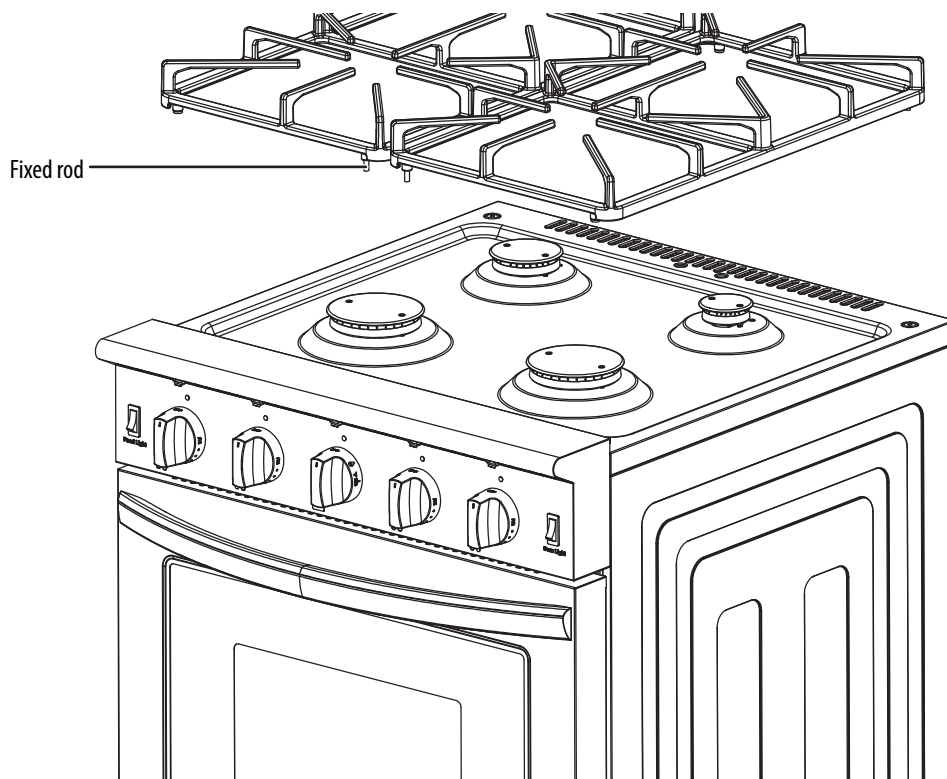

Cleaning the cook top burners

CAUTIONS:

- Do not remove the burners.
- Do not let water drip into the burners.

- 1 Remove the grate, clean it in warm, soapy water, then dry it with a dry cloth. If a stain is difficult to remove, use a plastic scrubber. See [Removing the cook top grate](#) on page 25.
- 2 Clean the burners with a damp, warm cloth.
- 3 Re-install the supports.

Cleaning the control panel

CAUTIONS:

- Do not remove the control knobs for cleaning. They may get damaged.
- Do not let water drip into the control panel or under the knobs.

- Wipe the control panel and knobs with a damp, warm cloth. If a stain is difficult to remove, use a plastic scrubber.

Cleaning the oven

- While the oven is warm (not hot), wipe it with a damp cloth.

CAUTIONS:

- Do not use oven cleaner or other cleaning agents to clean the oven. They may damage the oven interior.
- Do not let fat or oils build up on the oven base or oven accessories. If fat or oil splatters or drips, after cooking is complete, turn off the oven and remove the fat or oil while the oven is warm.

INSIGNIA™

3.7 Cu. Ft. Free-Standing Gas Range for RVs

Removing the storage drawer

- 1 At the same time, press down on the clip on the right side of the storage drawer and up on the clip on the left side of the storage drawer.

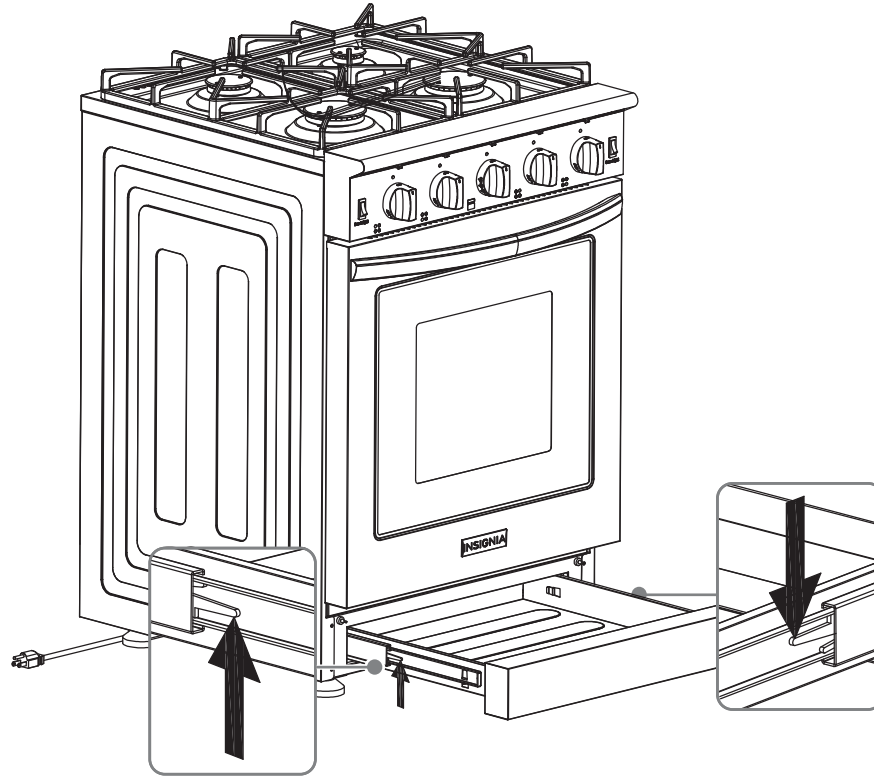

- 2 While holding the clips, pull the drawer until it separates from the groove on the guide rail, then remove the drawer.

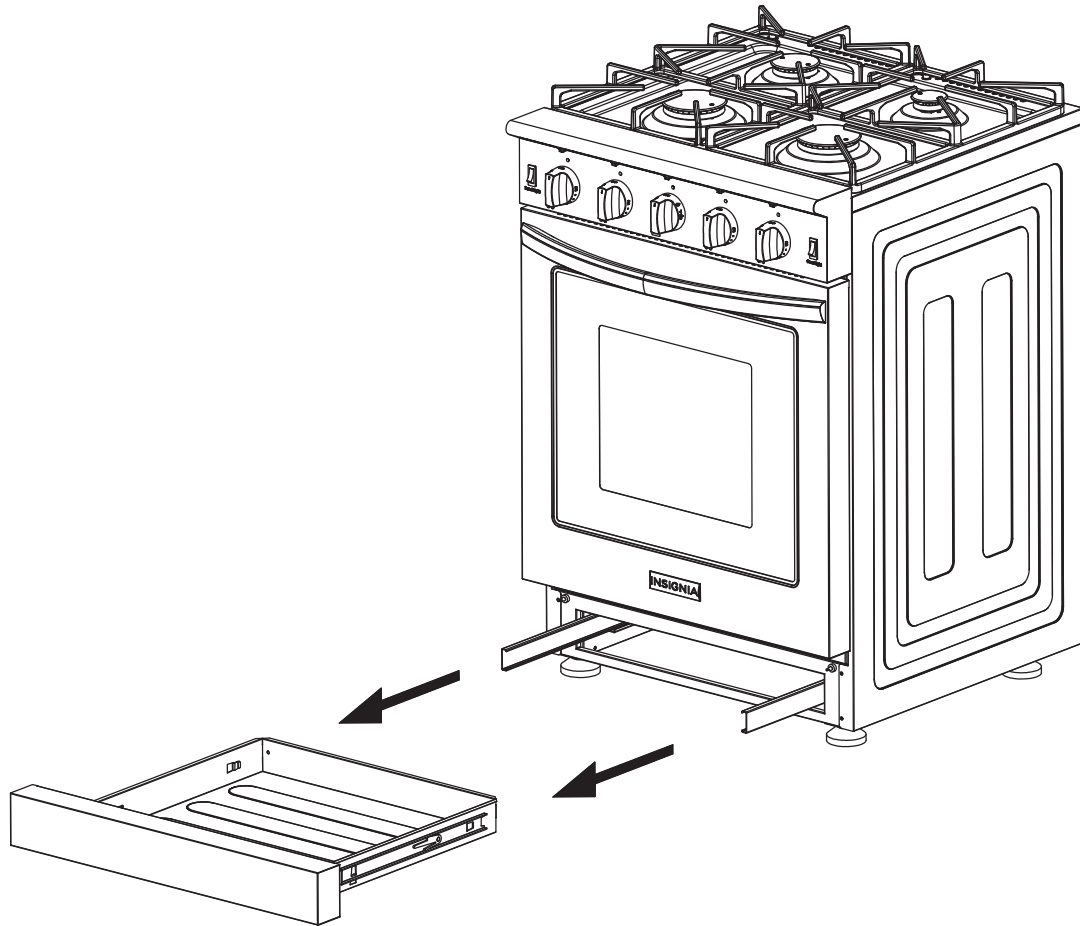

- 3 To replace the drawer, align it with the rails, press down on the clip on the left side of the drawer and up on the right side of the drawer, then slide the drawer back into your range.

INSIGNIA™

Disassembling range parts

CAUTION: To avoid potential damage or injury, these disassemble tasks should only be done by a qualified technician.

Disassembling the cook top burners

- 1 Remove the grate. See [Removing the cook top grate](#) on page 25.
- 2 Use a Phillips screwdriver to remove the two screws on a burner cap, then remove the cap and outer burner head.

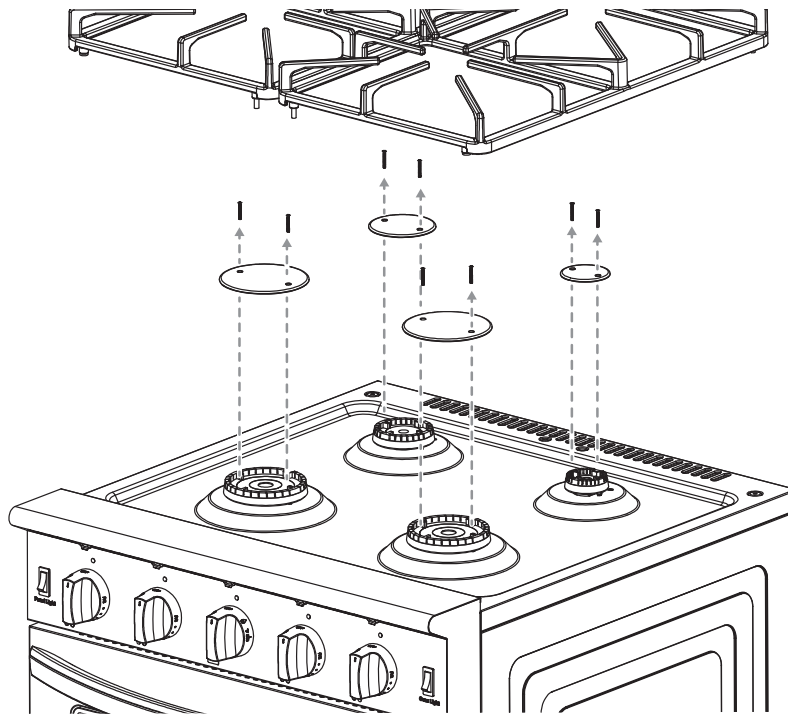

- 3 Remove the two screws on the burner base cap, then remove the cap and burner base.

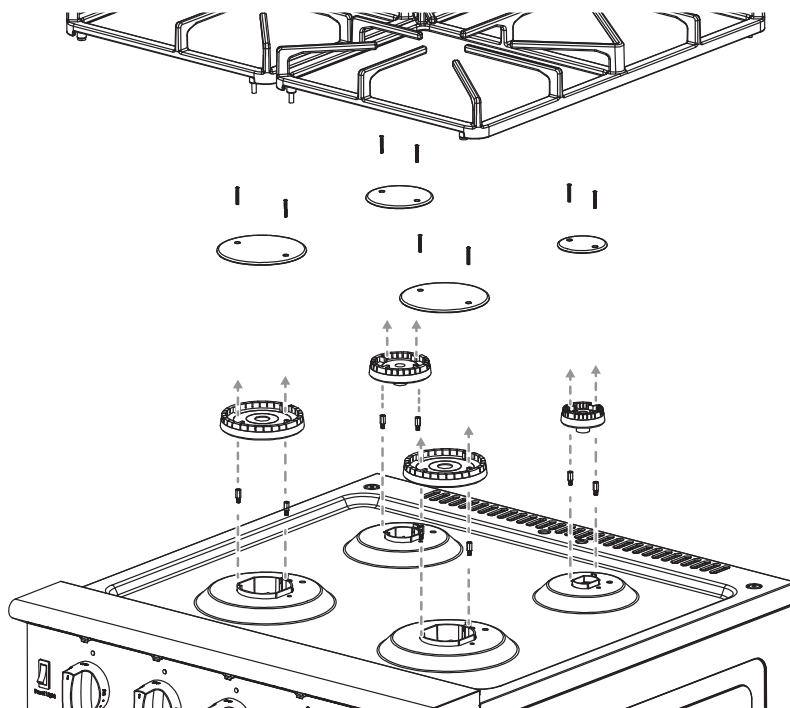

- 4 Reverse these steps to reinstall the burner.

Accessing the pilot light and oven burner

Note: The illustrations shown in this section are for reference only. The actual product may differ slightly.

- 1 Open the oven door.

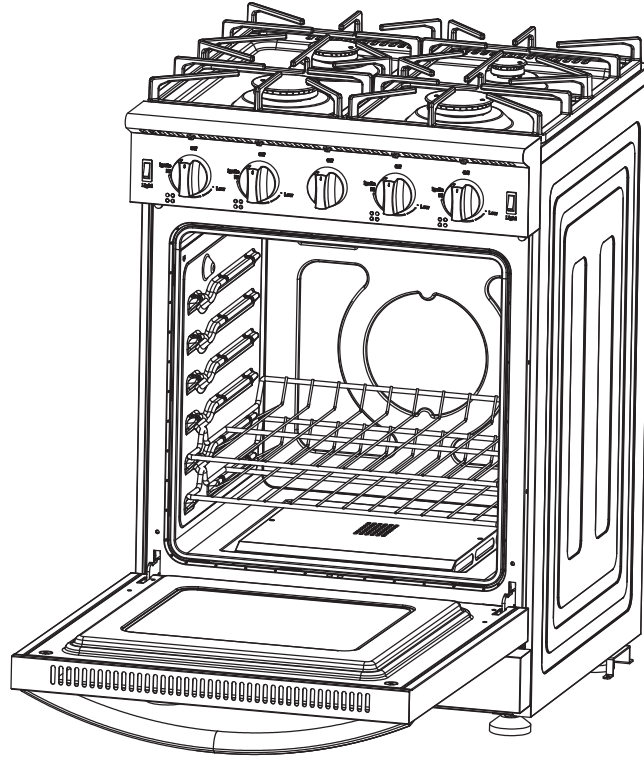

- 2 Remove the racks from the oven. To remove a rack, pull the rack toward you until it reaches the stop position, then tilt the front edge of the rack up and pull the rack completely out.

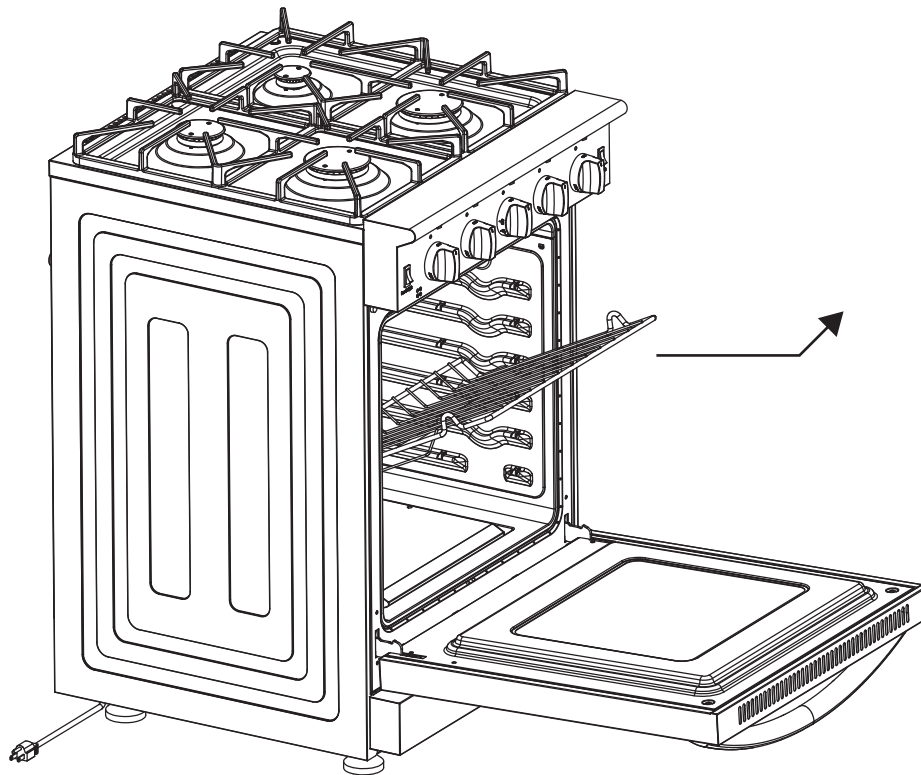

INSIGNIA™

3.7 Cu. Ft. Free-Standing Gas Range for RVs

- 3 Use a Phillips screwdriver to remove the two screws on the panel on the bottom of the oven, then remove the panel.

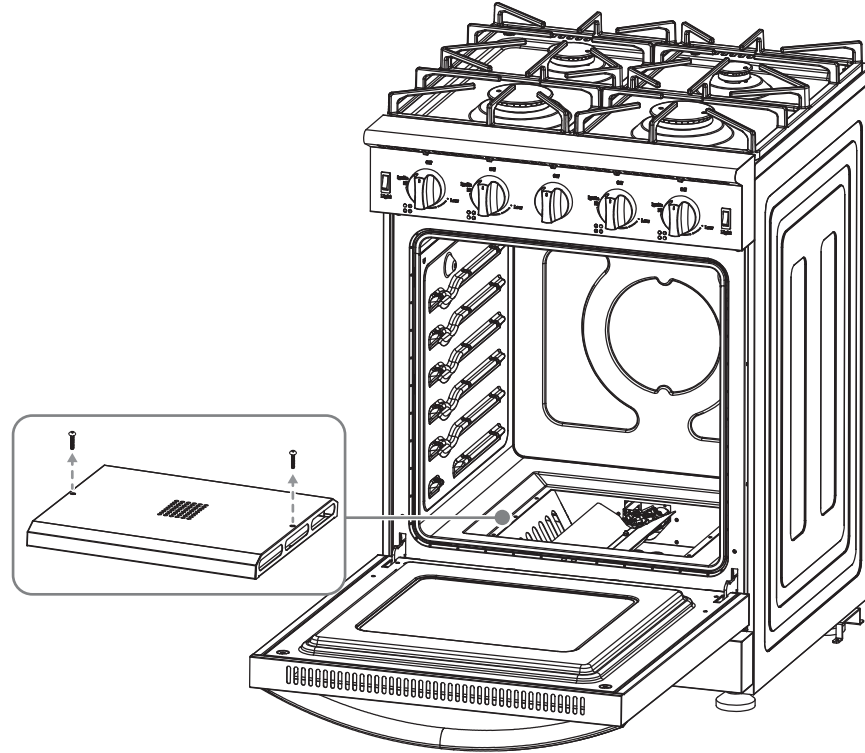

- 4 Remove the two screws from the pilot lamp and the single screw on the tube burner, then lift the lamp and burner up and out of the oven.

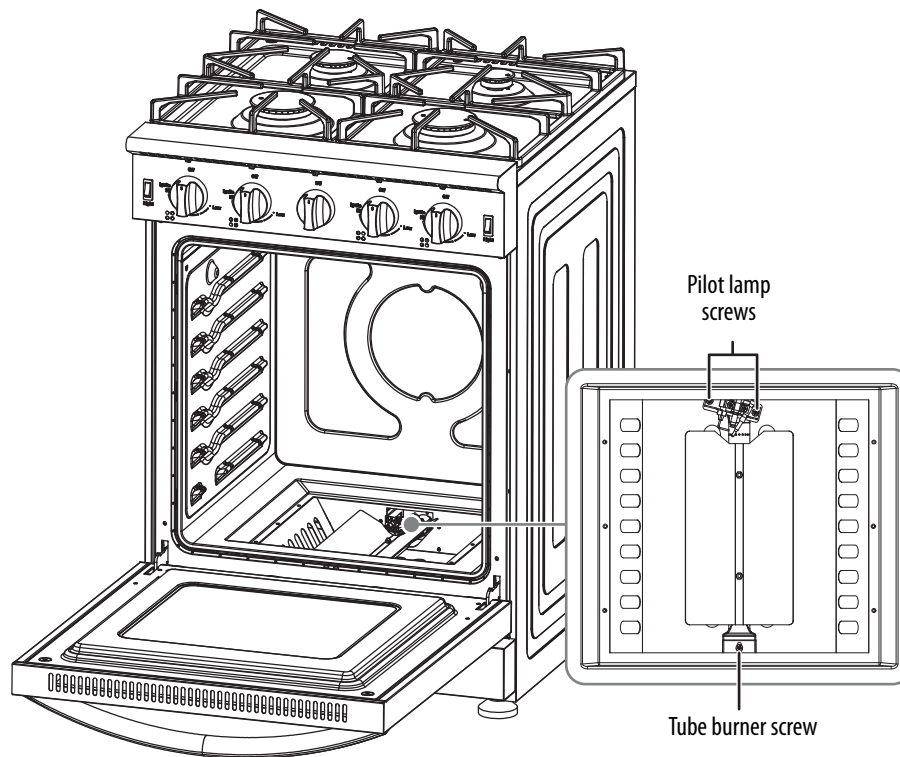

Removing and reinstalling the oven door

To remove the oven door:

- 1 Open the oven door to a 90° angle, then fully open the levers on each side.

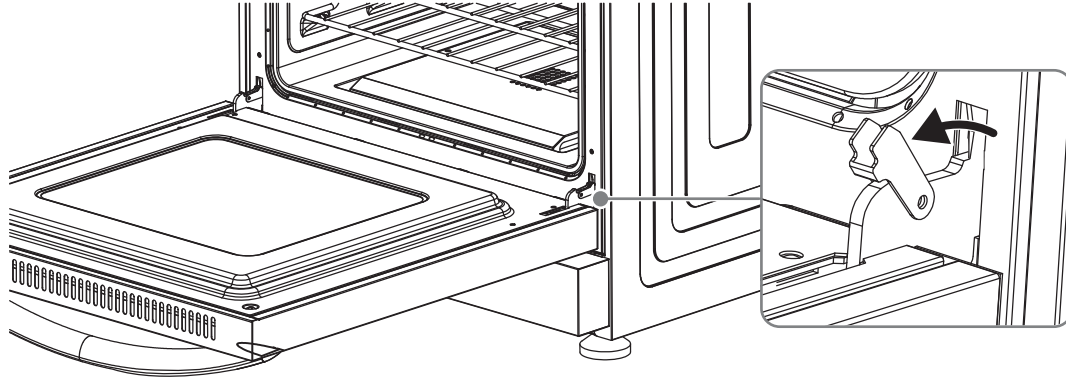

- 2 Gently close the door about halfway to disengage the hinges, then pull out the door and place it on a protected surface.

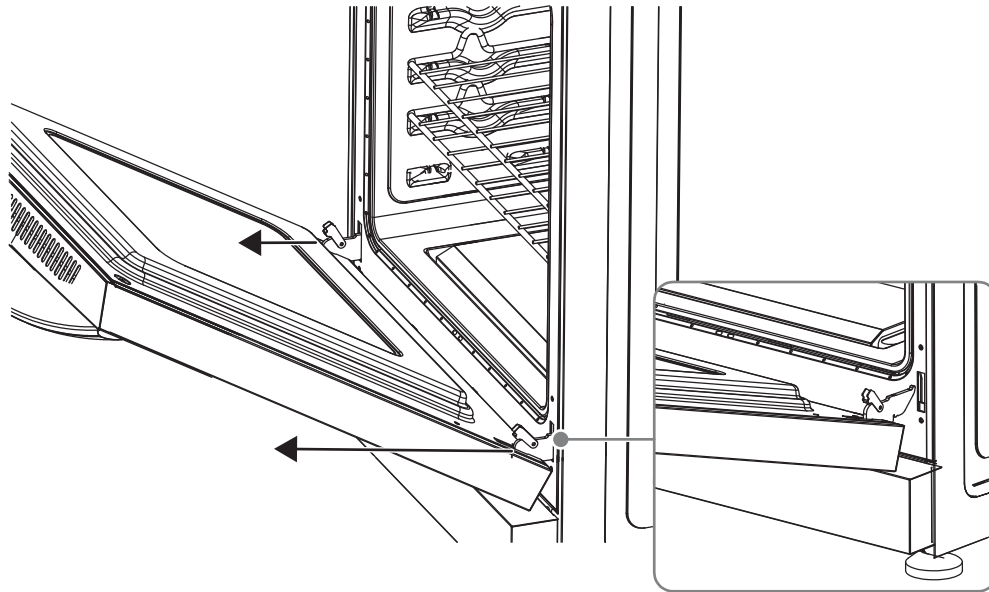

INSIGNIA™

3.7 Cu. Ft. Free-Standing Gas Range for RVs

To reinstall the oven door

- 1 While holding the door at approximately a 45° angle, insert the hinge tongues into the slots making sure that the notches on both sides slide into place.

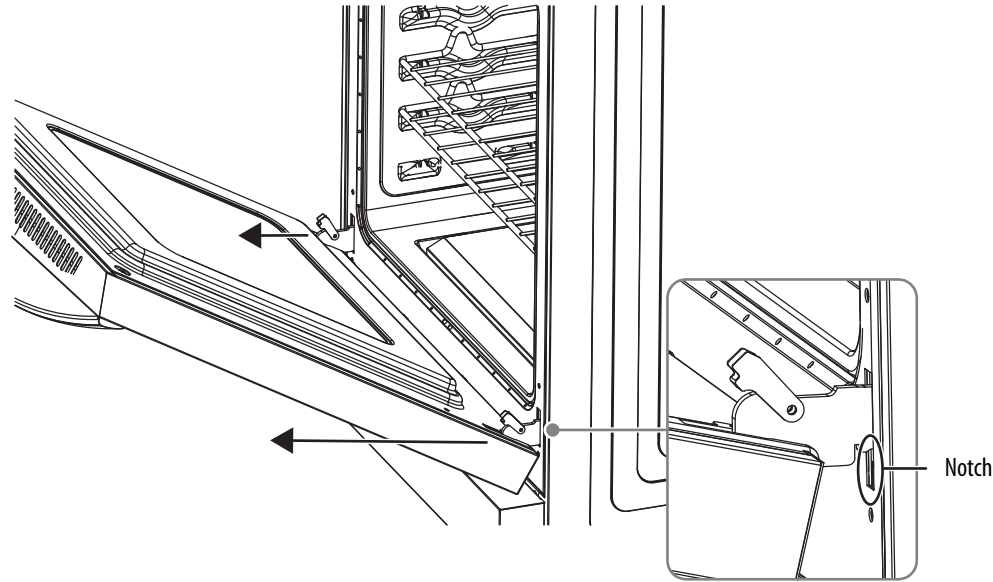

- 2 Carefully close the door. If the door does not easily close, do not force it. Make sure that the hinges are correctly installed.

Troubleshooting

Cook top

If the solutions in this section do not solve a problem, contact a qualified service technician or Insignia customer service.

PROBLEM	PROBABLE CAUSE	POSSIBLE SOLUTION
Some burners will not light	Burner parts or igniter may be wet, dirty, or misaligned	<ul style="list-style-type: none"> • Make sure that the burner parts are clean, dry, and correctly assembled. • Make sure that the igniters are clean and dry. For instructions on cleaning a cook top burner, see Cleaning the cook top burners on page 25.
Flames do not burn all around the burner cap	Burner parts or igniter may be wet, dirty, or misaligned	<ul style="list-style-type: none"> • Make sure that the burner parts are clean, dry, and correctly assembled. • Make sure that the igniters are clean and dry. For instructions on cleaning a cook top burner, see Cleaning the cook top burners on page 25.
Burner flames are unusually large and yellow	Burner bezel ports are clogged	Clean burner bezel ring ports with a straightened paper clip, needle, or wire.
	Burner ports or burner caps are not positioned correctly	Remove and carefully re-install the burner bezels and caps.
	Cook top is being operated with the wrong type of gas	Make sure that the type of cook top matches the LP gas supply.
	Regulator is not installed, is faulty, or is set for the wrong type of gas	Check the installation, replace the regulator, or set the regulator for the correct type of gas.
Ignition sparks, but there is no flame	Gas shut-off valve is in the OFF position	Turn the shut-off valve to the ON position.
Igniters spark continuously after flame ignites	Power supply polarity is reversed	Contact a service technician to have the polarity corrected.
	Igniters are wet or dirty	Dry or clean the igniters.

PROBLEM	PROBABLE CAUSE	POSSIBLE SOLUTION
Flames suddenly go out	An air draft has extinguished the flame	Make sure that an air draft does not blow directly on the cook top.
	A spill has extinguished the flame	Turn off the burners, let the cook top cool, then clean the burner and surrounding area. If the spill is large, we recommend that you disassemble and clean the burner and sump area. For instructions on disassembling a cook top burner, see Disassembling the cook top burners on page 28 .
	No LP gas	Make sure that you have not run out of LP gas. Refill the tank if needed.
Can I use the burners during a power outage?		<p>WARNING: If the flames are blown out when a power outage occurs, immediately turn off the burners. Gas may escape. The burners do not automatically re-light when power is restored. Yes, you use the cook top burners during a power outage.</p> <ol style="list-style-type: none"> 1 Holding a lighted match to the flame spreader, push in on the control knob and turn it counter-clockwise to the fire label. 2 When the flame is burning all the way around the burner, release the knob. 3 Adjust the heat if needed.

Oven

If the solutions in this section do not solve a problem, contact a qualified service technician or Insignia customer service.

PROBLEM	PROBABLE CAUSE	POSSIBLE SOLUTION
Oven does not heat	No power supply	<ul style="list-style-type: none"> • Make sure that the circuit breaker has not tripped. • Make sure that there is no power outage in your RV or area. If there is a power outage, you cannot use the oven until power has been restored. <p>WARNING: Do not try to light the oven with a match or lighter.</p>
	No LP gas	Make sure that you have not run out of LP gas. Refill the tank if needed.
	Oven settings are not correct	Follow the instructions in Turning on the oven on page 22 .
Oven does not maintain the temperature	The oven burner orifice is blocked.	Make sure that the oven burner orifice is not blocked. The orifice is in the pilot light and tube burner compartment. See Accessing the pilot light and oven burner on page 29 .
	The spray fire hole in the oven tube burner is blocked.	Make sure that the spray fire hole is not blocked. See Accessing the pilot light and oven burner on page 29 .
	The thermostat valve may be damaged.	Contact a qualified service technician to replace the thermostat valve.
Condensation around the oven control panel or the top of oven door	Food with a high moisture content or local climate conditions, like high temperature or humidity, can cause condensation	Condensation is normal. Wipe the condensation off the control panel or oven door. If you experience frequent or excessive condensation, make sure that the cabinetry around your range is moisture-proofed.
Steam comes from oven vents at the back of my range	Moisture from food is evaporating during cooking	This is normal, especially if you are cooking large quantities of food in the oven.
Food is over-cooked or under-cooked	Incorrect cooking time, temperature, or rack position	Adjust the cooking time, temperature, or rack position.

INSIGNIA™

3.7 Cu. Ft. Free-Standing Gas Range for RVs

PROBLEM	PROBABLE CAUSE	POSSIBLE SOLUTION
Cracking or popping sound	This is the sound of metal heating up or cooling down	This sound is normal.
Can I use the oven during a power outage?		No, do not try to use the oven during a power outage.

Specifications

Dimensions (W × D × H)	23.9 × 24 × 36 in. (60.7 × 61 × 91.4 cm)
Weight	Net Weight: 146.6 lbs. (66.5 kg) Gross Weight: 168.7 lbs. (76.5 kg)
Power requirements	110/120VAC 60 Hz
Power cord length	5 ft. (1.5 m)
Cook top	Rear left: Normal burner 6000BTU Front left: Normal burner 9000BTU Rear right: Auxiliary burner 3500BTU Front right: Rapid burner 12000BTU
Oven light	40W
Oven power consumption	12000 BTU
Gas type	Propane gas

ONE-YEAR LIMITED WARRANTY

Definitions:

The Distributor* of Insignia branded products warrants to you, the original purchaser of this new Insignia-branded product ("Product"), that the Product shall be free of defects in the original manufacturer of the material or workmanship for a period of one (1) year from the date of your purchase of the Product ("Warranty Period").

For this warranty to apply, your Product must be purchased in the United States or Canada from a Best Buy branded retail store or online at www.bestbuy.com or www.bestbuy.ca, and is packaged with this warranty statement.

How long does the coverage last?

The Warranty Period lasts for 1 year (365 days) from the date you purchased the Product. Your purchase date is printed on the receipt you received with the Product.

What does this warranty cover?

During the Warranty Period, if the original manufacture of the material or workmanship of the Product is determined to be defective by an authorized Insignia repair center or store personnel, Insignia will (at its sole option): (1) repair the Product with new or rebuilt parts; or (2) replace the Product at no charge with new or rebuilt comparable products or parts. Products and parts replaced under this warranty become the property of Insignia and are not returned to you. If service of Products or parts are required after the Warranty Period expires, you must pay all labor and parts charges. This warranty lasts as long as you own your Insignia Product during the Warranty Period. Warranty coverage terminates if you sell or otherwise transfer the Product.

How to obtain warranty service?

If you purchased the Product at a Best Buy retail store location, please take your original receipt and the Product to any Best Buy store. Make sure that you place the Product in its original packaging or packaging that provides the same amount of protection as the original packaging. If you purchased the Product from a Best Buy online web site (www.bestbuy.com or www.bestbuy.ca), mail your original receipt and the Product to the address listed on the web site. Make sure that you put the Product in its original packaging or packaging that provides the same amount of protection as the original packaging.

To obtain warranty service, in the United States and Canada call 1-877-467-4289. Call agents may diagnose and correct the issue over the phone.

Where is the warranty valid?

This warranty is valid only in the United States and Canada at Best Buy branded retail stores or websites to the original purchaser of the product in the country where the original purchase was made.

What does the warranty not cover?

This warranty does not cover:

- Food loss/spoilage due to failure of refrigerator or freezer
- Customer instruction/education
- Installation
- Set up adjustments
- Cosmetic damage
- Damage due to weather, lightning, and other acts of God, such as power surges
- Accidental damage
- Misuse
- Abuse
- Negligence
- Commercial purposes/use, including but not limited to use in a place of business or in communal areas of a multiple dwelling condominium or apartment complex, or otherwise used in a place of other than a private home.
- Modification of any part of the Product, including the antenna
- Display panel damaged by static (non-moving) images applied for lengthy periods (burn-in).
- Damage due to incorrect operation or maintenance
- Connection to an incorrect voltage or power supply
- Attempted repair by any person not authorized by Insignia to service the Product
- Products sold "as is" or "with all faults"
- Consumables, including but not limited to batteries (i.e. AA, AAA, C etc.)
- Products where the factory applied serial number has been altered or removed
- Loss or Theft of this product or any part of the product
- Display panels containing up to three (3) pixel failures (dots that are dark or incorrectly illuminated) grouped in an area smaller than one tenth (1/10) of the display size or up to five (5) pixel failures throughout the display. (Pixel based displays may contain a limited number of pixels that may not function normally.)
- Failures or Damage caused by any contact including but not limited to liquids, gels or pastes.

REPAIR REPLACEMENT AS PROVIDED UNDER THIS WARRANTY IS YOUR EXCLUSIVE REMEDY FOR BREACH OF WARRANTY. INSIGNIA SHALL NOT BE LIABLE FOR ANY INCIDENTAL OR CONSEQUENTIAL DAMAGES FOR THE BREACH OF ANY EXPRESS OR IMPLIED WARRANTY ON THIS PRODUCT, INCLUDING, BUT NOT LIMITED TO, LOST DATA, LOSS OF USE OF YOUR PRODUCT, LOST BUSINESS OR LOST PROFITS. INSIGNIA PRODUCTS MAKES NO OTHER EXPRESS WARRANTIES WITH RESPECT TO THE PRODUCT, ALL EXPRESS AND IMPLIED WARRANTIES FOR THE PRODUCT, INCLUDING, BUT NOT LIMITED TO, ANY IMPLIED WARRANTIES OF AND CONDITIONS OF MERCHANTABILITY AND FITNESS FOR A PARTICULAR PURPOSE, ARE LIMITED IN DURATION TO THE WARRANTY PERIOD SET FORTH ABOVE AND NO WARRANTIES, WHETHER EXPRESS OR IMPLIED, WILL APPLY AFTER THE WARRANTY PERIOD. SOME STATES, PROVINCES AND JURISDICTIONS DO NOT ALLOW LIMITATIONS ON HOW LONG AN IMPLIED WARRANTY LASTS, SO THE ABOVE LIMITATION MAY NOT APPLY TO YOU. THIS WARRANTY GIVES YOU SPECIFIC LEGAL RIGHTS, AND YOU MAY ALSO HAVE OTHER RIGHTS, WHICH VARY FROM STATE TO STATE OR PROVINCE TO PROVINCE.

Contact Insignia:

For customer service please call 1-877-467-4289

www.insigniaproducts.com

INSIGNIA is a trademark of Best Buy and its affiliated companies.

Distributed by Best Buy Purchasing, LLC

7601 Penn Ave South, Richfield, MN 55423 U.S.A.

©2019 Best Buy. All rights reserved.

Made in China

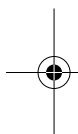

INSIGNIA™

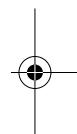

For product inquiries, please contact us with the information below:

1-877-467-4289

www.insigniaproducts.com

INSIGNIA is a trademark of Best Buy and its affiliated companies.

Distributed by Best Buy Purchasing, LLC

7601 Penn Ave South, Richfield, MN 55423 U.S.A.

©2019 Best Buy. All rights reserved.

Made in China

V4 ENGLISH
19-0328

